

LET	CH NO.	BY	DATE	REVISIONS
-	7530	JTP	10/24/13	RELEASED

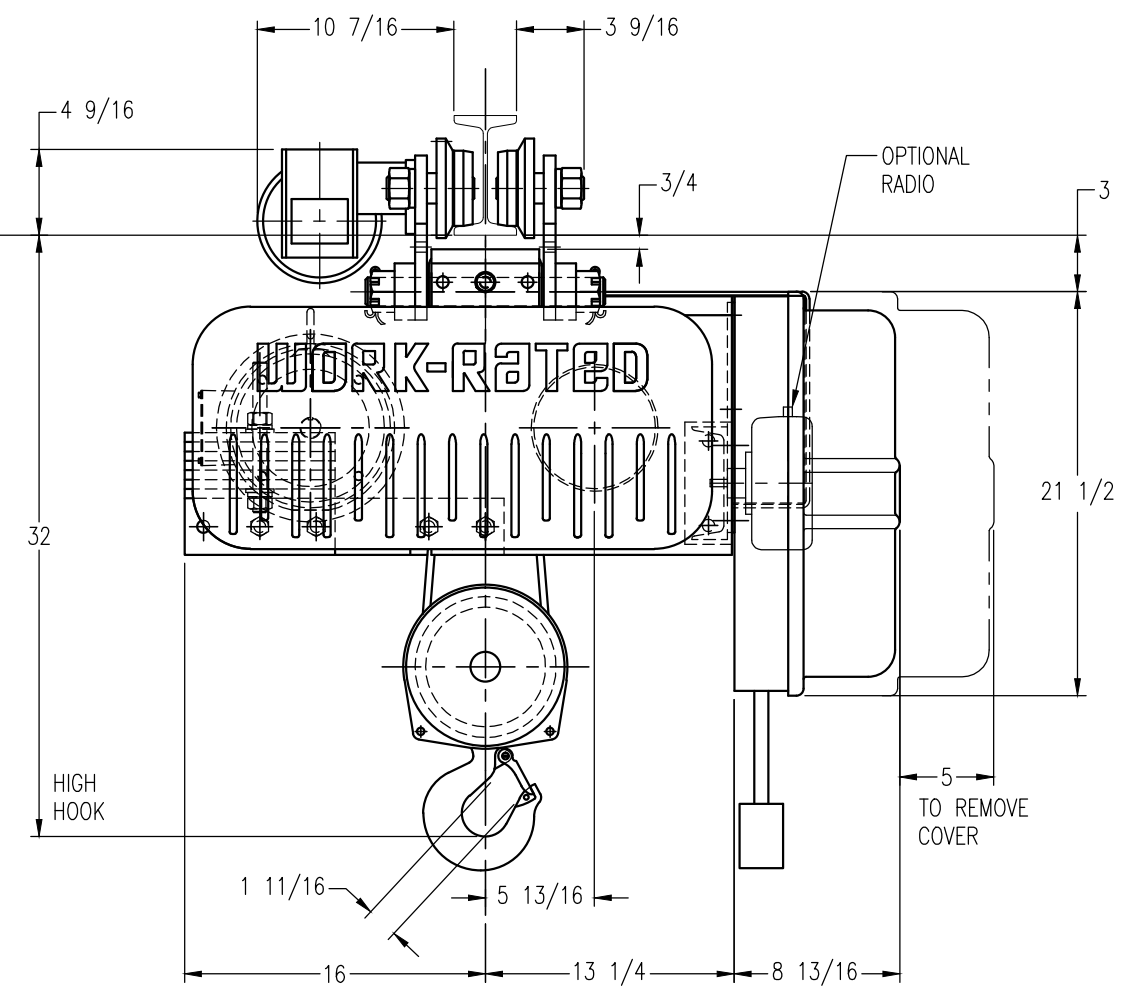
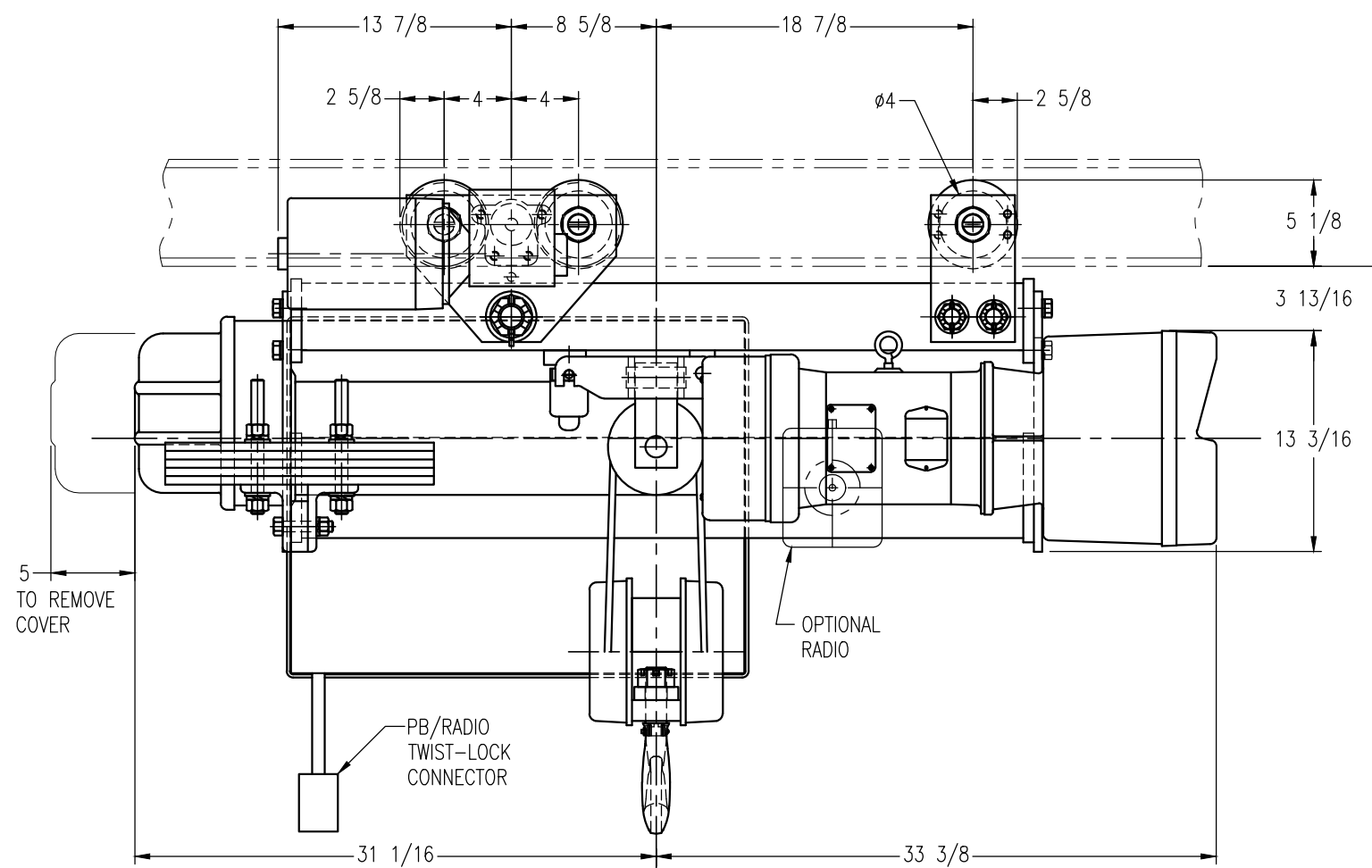

CUSTOMER:  
 CUSTOMER P.O. No.:  
 ACCO PRODUCT No.: C2W05D036-15M2D1  
 CAPACITY: 5 TONS  
 LIFT: 36 FT  
 LIFTING SPEED: 15 FPM, 5 HP  
 TRAVEL SPEED: 50 FPM, 0.5 HP

POWER SUPPLY: 230/460-3-60  
 BEAM:  
 REMARKS:  
 ACCO ORDER No.:  
 SERIAL No.:

ITEM	REV'D	QTY	UNIT	DESCRIPTION	LENGTH	WT.																																																															
<table border="1"> <tr> <td colspan="2">NEXT ASSY NO.</td> <td>REV'D</td> <td colspan="2">METALLURGY APPROVED</td> <td colspan="2">ACCO MATERIAL HANDLING SOLUTIONS</td> </tr> <tr> <td colspan="2"></td> <td>BY:</td> <td>DATE:</td> <td colspan="2">76 ACCO DR. YORK, PA 17402</td> <td></td> </tr> <tr> <td colspan="2">UNLESS OTHERWISE SPECIFIED</td> <td colspan="2">CHECKED</td> <td colspan="2">NAME:</td> <td></td> </tr> <tr> <td colspan="2">BREAK ALL SHARP EDGES</td> <td colspan="2">BY:</td> <td colspan="2">DATE:</td> <td></td> </tr> <tr> <td colspan="2">TOLERANCES ON DIMENSIONS ARE:</td> <td colspan="2">APPROVED</td> <td colspan="2">Sr32 HOIST, 2PD</td> <td></td> </tr> <tr> <td colspan="2">THREE PLACE DECIMAL (.000)</td> <td colspan="2">BY:</td> <td colspan="2">DATE:</td> <td></td> </tr> <tr> <td colspan="2">TWO PLACE DECIMAL (.00)</td> <td colspan="2">REGISTER NO.</td> <td colspan="2">MOTORIZED TROLLEY</td> <td></td> </tr> <tr> <td colspan="2">ONE PLACE DECIMAL (.0)</td> <td colspan="2">ANGLES ±1°</td> <td colspan="2">MATERIAL:</td> <td></td> </tr> <tr> <td colspan="2">FRACTIONS ±1/32</td> <td colspan="2"></td> <td colspan="2">HEAT TREAT:</td> <td></td> </tr> </table>							NEXT ASSY NO.		REV'D	METALLURGY APPROVED		ACCO MATERIAL HANDLING SOLUTIONS				BY:	DATE:	76 ACCO DR. YORK, PA 17402			UNLESS OTHERWISE SPECIFIED		CHECKED		NAME:			BREAK ALL SHARP EDGES		BY:		DATE:			TOLERANCES ON DIMENSIONS ARE:		APPROVED		Sr32 HOIST, 2PD			THREE PLACE DECIMAL (.000)		BY:		DATE:			TWO PLACE DECIMAL (.00)		REGISTER NO.		MOTORIZED TROLLEY			ONE PLACE DECIMAL (.0)		ANGLES ±1°		MATERIAL:			FRACTIONS ±1/32				HEAT TREAT:		
NEXT ASSY NO.		REV'D	METALLURGY APPROVED		ACCO MATERIAL HANDLING SOLUTIONS																																																																
		BY:	DATE:	76 ACCO DR. YORK, PA 17402																																																																	
UNLESS OTHERWISE SPECIFIED		CHECKED		NAME:																																																																	
BREAK ALL SHARP EDGES		BY:		DATE:																																																																	
TOLERANCES ON DIMENSIONS ARE:		APPROVED		Sr32 HOIST, 2PD																																																																	
THREE PLACE DECIMAL (.000)		BY:		DATE:																																																																	
TWO PLACE DECIMAL (.00)		REGISTER NO.		MOTORIZED TROLLEY																																																																	
ONE PLACE DECIMAL (.0)		ANGLES ±1°		MATERIAL:																																																																	
FRACTIONS ±1/32				HEAT TREAT:																																																																	
<small>This document and all data contained herein is the property of ACCO and is supplied in confidence for evaluation purposes only and under the express condition that it is not to be reproduced or transmitted to others without written authorization, is not to be used in any way detrimental to the interests of ACCO and is to be returned upon demand.</small>																																																																					
<small>DR BY: JTP</small> <small>DATE: 10/24/13</small> <small>SCALE: 1/5</small>				<b>D</b> 3285180		SHEET -																																																															